

Note:  
 Stop Location Should  
 Provide  $25^\circ \pm 2^\circ$  Up Travel  
 And  $15^\circ \pm 2^\circ$  Down Travel  
 On Elevator

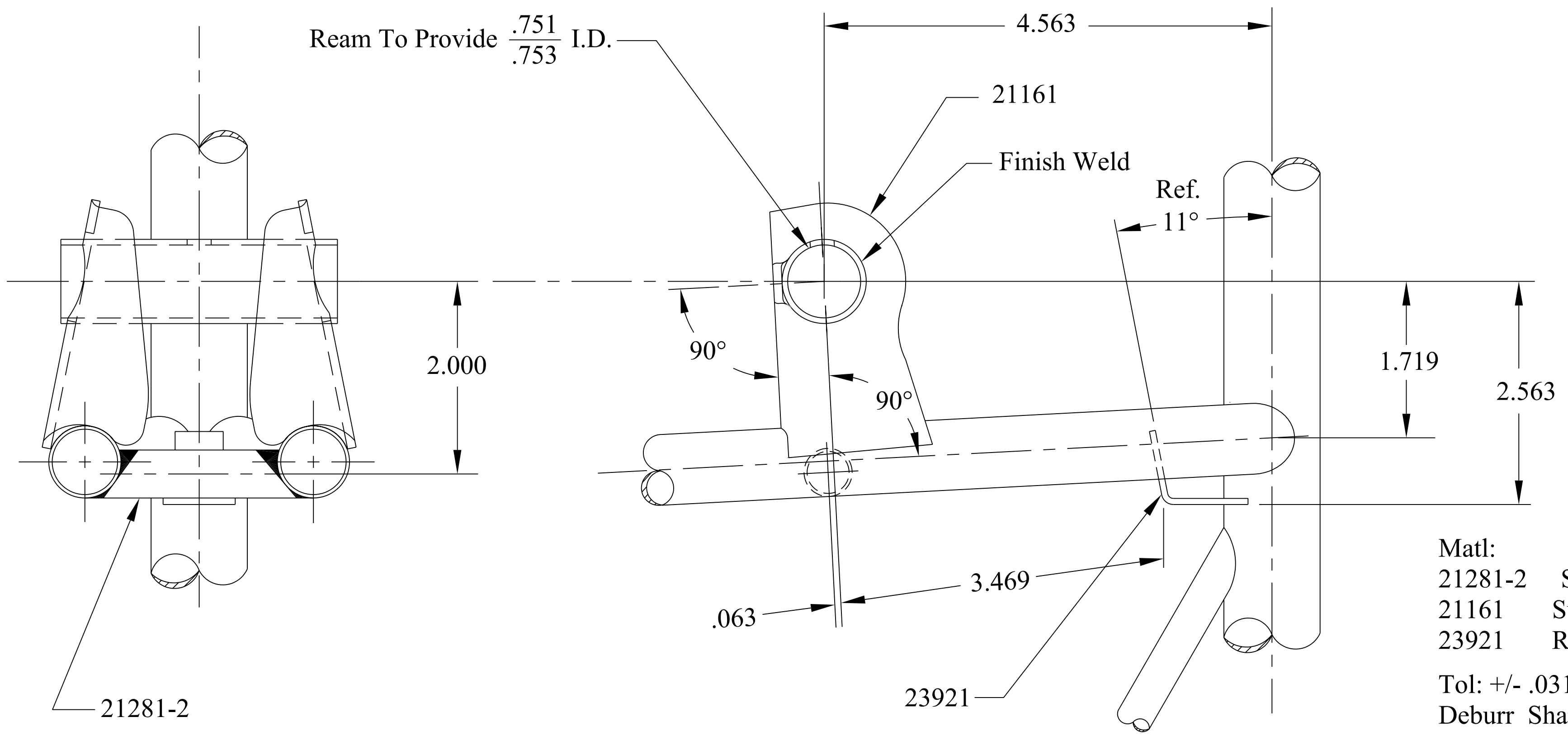

Matl:		No. Req.
21281-2	Stop	1
21161	Support Ass'y	1
23921	Rear Stop	1

Tol: +/- .031 Unless Otherwise Noted  
 Deburr Sharp Edges

Stop May Be Rotated About  
 Its Horizontal Axis To Obtain  
 Clearance With Adjacent  
 Fuselage Members

1 Required Per Plane

**North Land Aircraft**  
 Palmer, Alaska

Stops Installation - Stabilizer  
 Support & Elevator

Drawn By: LA | Date: 9-24-01 | Scale: 1=1

PA-18 | NL 23932